

HLT GEHÄUSEADAPTER VESA®

HLT CASING ADAPTOR VESA®

Art. Nr. / Part No.:
40112-01



Illustrative Abbildung / kein Lieferumfang
Sample illustration / not included in delivery



- ▶ Anbindung an HLT Tragarmsystem
Connection at the HLT suspension system
- ▶ Schutzart IP 54
Protection class IP 54
- ▶ VESA® 75 oder 100 (option) möglich
VESA® 75 and 100(option) possible
- ▶ Optional Kabelauslass beidseitig möglich
Both-way cable ducting system possible (option)
- ▶ Farbe: ähnlich RAL 7016 (Anthrazitgrau)
Color: similar to RAL 7016 (anthracite grey)
- ▶ Gewicht: ca 1,2 kg
Weight: approx. 1,2 kg

Zubehör (optional) / Accessories (optional):
VESA 100 Adapterplatte Art. Nr.: 40190-02
VESA 100 adaptor plate Part No.: 40190-02

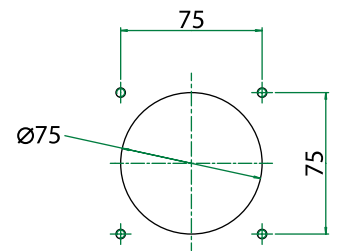
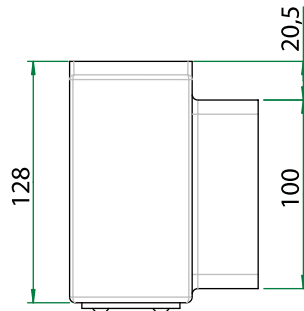
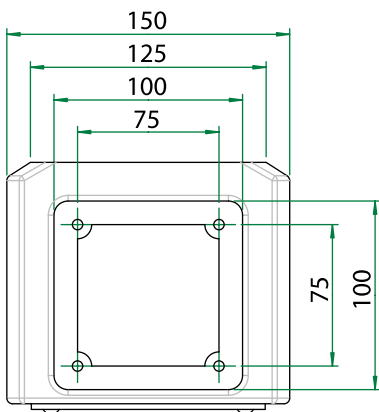

Anschlussmaß
Drilling template

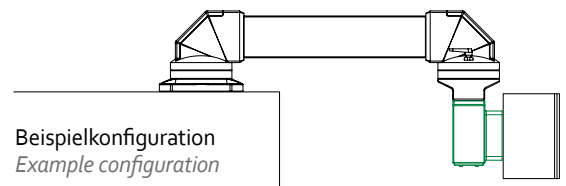
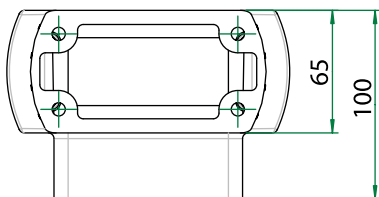

Beispielkonfiguration
Example configuration

Alle Angaben in mm / All specifications in mm

HASEKE
INDUSTRY